

OWNER'S MANUAL

12 Volt Pro UTV Sprayers

Model: PROUTV65-12V-M

(5303225)

(65 Gallon UTV Sprayer, Boom Ready)

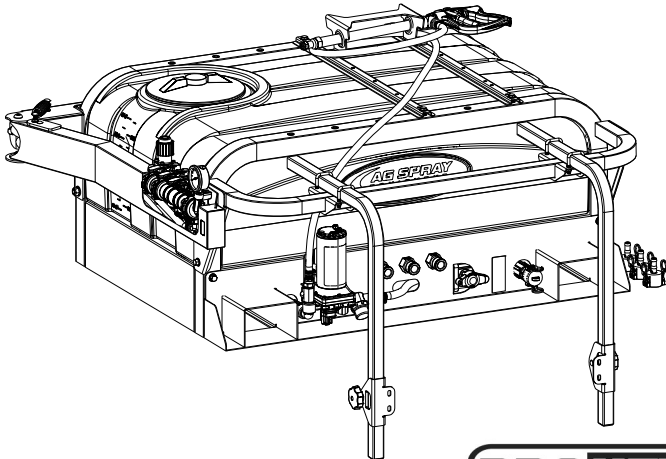

Model: PROUTV105-12V-M

(5303230)

(105 Gallon UTV Sprayer, Boom Ready)

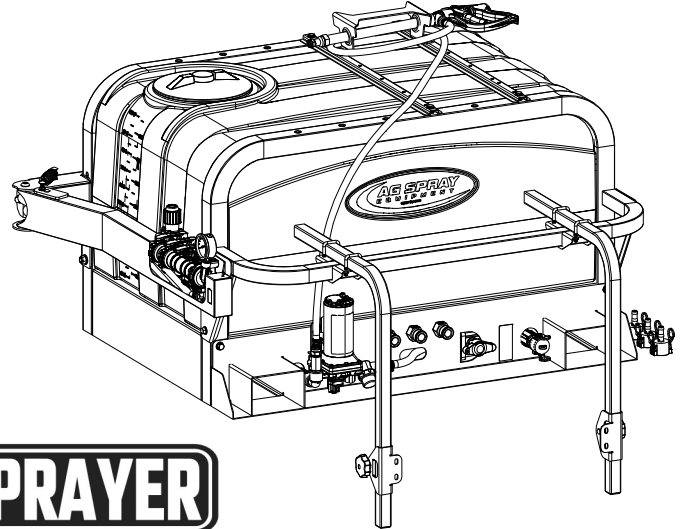

PROUTV SPRAYER

AG SPRAY PRO SERIES

General Information

Thank you for purchasing this product. The purpose of this manual is to assist you in operating and maintaining your UTV sprayer.



WARNING: To reduce the risk of injury, the user must read and understand the operator's manual before using this product.



WARNING: Cancer and Reproductive Harm
www.P65Warnings.ca.gov

BEFORE RETURNING THIS PRODUCT FOR ANY REASON, PLEASE CALL

BAKERSFIELD, CA 877-724-2236	COLUMBUS, NE 800-274-1025	DOTHAN, AL 800-227-4098
FARGO, ND 701-280-2862	HOPKINSVILLE, KY 800-637-7172	MANKATO, MN 507-388-6295
NEWTON, KS 800-394-7662	PASCO, WA 800-634-2026	TEMPE, AZ 877-974-7166

If you should have a question or experience a problem with your Ag Spray Product: Visit our website @ www.agspray.com or call the Toll free number above. Our technical support representatives will be happy to help you.

In most cases a customer service rep. can resolve the problem over the phone.

To obtain prompt, efficient service, always remember to give the following information....

- Correct Part Description and/or part number
- Model number and Serial Number

Part descriptions and numbers can be obtained from the illustrated parts list section(s) of this manual.

Retain a copy of your receipt for your unit, as it will be required to validate any warranty service.

Warranted against manufacturer or workmanship defects from date of purchase with copy of receipt:

Homeowner Usage: One Year

Commercial Usage: 90 Days.

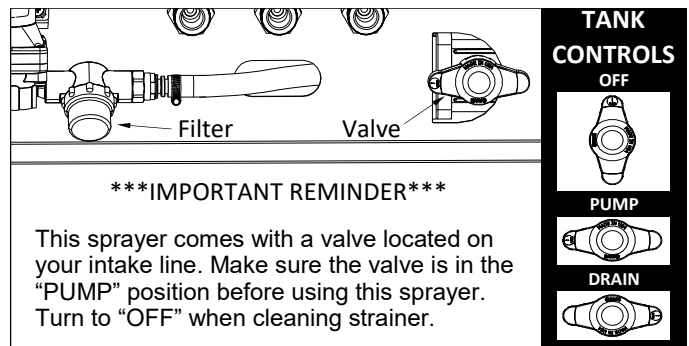

IMPORTANT REMINDER

This sprayer comes with a valve located on your intake line. Make sure the valve is in the "PUMP" position before using this sprayer. Turn to "OFF" when cleaning strainer.



www.agspray.com

[5195666

(05/22)]



12 Volt Pro UTV Sprayers

Model: PROUTV65-12V-M

(5303225)

(65 Gallon UTV Sprayer, Boom Ready)
Approx. Sprayer Weight when filled w/water
755 Lbs.

Model: PROUTV105-12V-M

(5303230)

(105 Gallon UTV Sprayer, Boom Ready)
Approx. Sprayer Weight when filled w/water
1,110 Lbs.

Always check the vehicle load rating before using this sprayer. Do not exceed the recommended rating.

Contents

Technical Specs and Assembly Instructions	3	PROUTV65-12V-M Exploded Views.....	7 - 9
Testing the Sprayer	3	PROUTV65-12V-M Parts List	9
Operation and Calibration.....	4	PROUTV105-12V-M Exploded Views.....	10 - 12
Maintenance and Winter Storage	4	PROUTV105-12V-M Parts List	12
Tank Care	5	Sprayer Dimensions.....	13
Troubleshooting	5 - 6	Warranty.....	14

IMPORTANT

Remove tank lid and be sure the tank is clean and free of any foreign material. Rinse tank out of any tank residue before filling with water to test.

IMPORTANT

It is VERY important to test this sprayer with plain water before actual spraying is attempted. This will enable you to check the sprayer for leaks without the possibility of losing any expensive chemicals.

WARNING



Read and Understand the Owner's Manual before using this sprayer. Test and use in accordance to instructions.

Read and Follow chemical label instructions and wear protective gear when filling, using, cleaning and servicing the sprayer.

Exercise Caution in vehicle handling when towing/hauling a filled sprayer to avoid loss of control or overturning.

Keep Sprayer and Spray materials away from other people, children and pets.

Do Not Turn on Power to the sprayer, until ready to spray in order to avoid unintentional spray release.

Do Not Use on steep slopes. A full sprayer could cause loss of control or overturn sprayer and vehicle.

Always operate up and down a slope, never across the face of a slope.

Keep all movement on slopes slow and gradual. Do not make sudden changes in speed, directions or turning. Do not start or stop suddenly when going uphill or downhill.

Stop on level ground, set the parking brake and shut off engine before leaving the operator's position for any reason.

Keep all parts in good condition and properly installed. Fix damaged or worn parts immediately.

Caution should be taken when towing and/or using any sprayer. This sprayer combined with the weight distribution, turning radius and speed of vehicle can result in damage to vehicle and/or sprayer or severe injury or death, if not used properly.

Improper use of this sprayer or handling of chemicals could result in serious injury or illness, or could cause damage to the environment.



Technical Specifications

- 65 or 105 Gallon Corrosion-Resistant Polyethylene Tank
- ProSeries 22" HP Long Range Ergonomic Handgun
- 25 Ft. Handgun Hose
- 27 Ft. Max. Vertical Throw, 38 Ft. Horizontal Throw
- 12 Volt, 5.3 GPM ShurFlo Pump
- Molded-In Tank Baffle w/Sloped Floor
- Molded-In Outlet Fitting for Complete Cleanout
- 3-Section Manual Control Swing Arm w/Position Detents

OPTIONS

- 50' Manual Hose Reel w/180° Swivel
- Booms: Traditional 13' to 28' or Boomless 40' Coverage

The PROFESSIONAL SERIES is designed with many features to make operation more user friendly with years of trouble free use.

Assembly Instructions

The sprayer is assembled already at the factory. The only assembly you will need to do is attaching optional boom or hose reel when purchased.

Connect the electrical hook-up to the unit and connect the wires to a fully charged battery.

Read the operating instructions and then run the sprayer using only water for testing. When everything tests all right, add the desired chemical mixture and water combination and start the spraying operation.

IMPORTANT: Remove tank lid and be sure the tank is clean and free of any foreign material. Rinse tank out of any tank residue before filling with water to test.

Testing the Sprayer

NOTE:

It is VERY important to test this sprayer with plain water before actual spraying is attempted. This will enable you to check the sprayer for leaks without the possibility of losing any expensive chemicals.

Fill the tank about 1/2 full with plain water and drive to the starting place for spraying.

When you are ready to spray, turn the pump on with the switch mounted in the control arm, then turn the boom valve to the "on" position (if applicable). This will start solution spraying from the tips of the boom. The pressure will decrease slightly when the boom is spraying.

Adjust the pressure by using the control valve mounted on the control arm. Make sure your pattern is sufficient. You may down-pressure the system by 'bypassing' solution back into the tank. This is achieved by opening the bypass/control valve. Regulating pressure is done in this manner.

Read the operating instructions and initially begin spraying by closing the bypass valve and opening the boom line valve. This will enable the air in the line to be eliminated (purged) through all the tips, while building pressure. When everything tests all right (no leaks and good pressure), add the desired chemicals to the mixture and water combination and start your spraying operation. Adjust the pressure and spray as you did in the testing procedure.

Conditions of weather and terrain must be considered when setting the sprayer. Do not spray on windy days. Protective clothing must be worn in some cases.

Be sure to read the chemical label(s) before application!

Operation

The pumping system draws solution from the tank, through the strainer and to the pump. The pump forces the solution under pressure to the handgun or boom nozzles.

Fill the tank part way with water and then add the desired amount of chemical to be sprayed. Finish filling tank to proper level. **Only fill the tank with what you're going to spray in a day, never leave chemicals sit in tank.**

Connect the lead wire to a fully charged 12 volt battery. You may use either a stand-alone battery or the battery on your towing vehicle. Connect to the positive (red) terminal first, then connect to the negative (black) terminal. Then connect the end of the lead wire to the unit connection. When disconnecting, disconnect the unit connection wire from the lead wire, then disconnect the negative (black) connection and finally the positive (red) connection. The control arm has an On/Off switch to activate the pump. "-" is on and "O" is off.

Turn the pump on and by depressing the "-" side of the rocker switch. The pump is equipped with a pressure switch that is pre-set at the factory to shut the pump off when all discharges are closed.

The pump will turn back on when one of the following actions occurs:

- ◆ Handgun lever is squeezed to spray the handgun.
- ◆ Boom valve is opened to broadcast spray with the boom.
- ◆ Bypass valve is opened to re-circulate solution back into the tank.

When spraying with either the boom (if applicable) or the handgun, pressure may be reduced by slowly opening the bypass valve until desired pressure is achieved. Opening the valve decreases pressure, closing the valve increases pressure. When spraying with the boom, the proper method to set the pressure is to open the boom valve completely and if a lower pressure is desired, then slowly open the pressure adjust valve until that pressure is obtained.

For the safest and most efficient chemical application, you will need to calibrate your sprayer using the tip and speed charts, in your optional boom manual. Once you have determined the proper speed and pressure settings, you will need to consult your chemical label for the amount of chemical to be added to the tank. Read the entire label. Use only according to label directions.

Calibration

Chemical labels may show application rates in gallons per acre, gallons per 1000 square feet or gallons per 100 square feet. Once you know how much you are going to spray, then determine your spraying pressure (PSI), and the spraying speed (MPH). Follow instructions in your boom manual, for calibration.

Add water and proper amount of chemical to the tank and drive to the starting place for spraying.

Maintenance During/After Spraying

Periodically check the strainer and clean the screen on your intake line.

If sprayer becomes clogged during use, discontinue use immediately. DO NOT attempt to service while chemicals are in the sprayer and power is connected.

Proper care and maintenance will prolong the life of your sprayer.

After use, drain the tank and store or dispose of chemical properly. Fill the sprayer half way with clean water. Start the pump and allow the water to pump through the entire plumbing system and nozzles. Drain and then refill half full, add the recommended amount of a good quality tank cleaner, such as FIMCO Tank Neutralizer and Cleaner. (If no tank cleaner is available, you may substitute dish soap for this step, about 1-2 oz. per gallon). But a neutralizer/cleaner should be used to thoroughly clean the system. Turn pump on and circulate through system for 15 minutes and then spray out through boom and handgun nozzles. Refill sprayer half way with clean water and repeat. Follow the chemical manufacturer's disposal instructions of all wash or rinsing water.

WARNING: Some chemicals will damage the pump valves if allowed to soak untreated for a length of time! ALWAYS flush the pump as instructed after each use. DO NOT allow chemicals to sit in the pump for extended times of idleness. Follow the chemical manufacturer's instructions on disposal of all waste water from the sprayer.

Winter Storage

Prepare the sprayer for end-of-season storage by running RV antifreeze through the system. This will keep internal parts lubricated, protect against corrosion and keep the unit from freezing. *Note: RV antifreeze is non-toxic and biodegradable and generally safer for the environment than automotive antifreeze.*

Before storing your sprayer for winter or long term storage, thoroughly clean and drain it as much as possible. Then pour enough pink RV antifreeze into the tank so that when the pump is turned on you can pump the antifreeze throughout the entire plumbing system, including the bypass. Make sure to operate the boom and handgun until you see pink fluid spraying from the nozzles. Leave any remaining antifreeze in the tank. Before your next usage, rinse the antifreeze from the sprayer with clean water.

It is nearly impossible to drain all of the water from the sprayer and any trapped water can freeze in cold weather and damage parts of the sprayer. Pumping the antifreeze through the system will displace the water and help prevent this damage.

Removing from storage: drain the antifreeze. Fill the tank with fresh water and run through the system. Dispose of antifreeze and flush water properly.

Tank Care & Maintenance

Warning: Do not use the tank as a container for fuel oils, kerosene, gasoline or any other petroleum distillate product. All polyolefins are softened and permeated by such products. In an enclosed area the vaporization of these materials from the outside surface of the tank could create a dangerous condition.

The tank should not be used as a pressure vessel nor used with chemicals or solutions having a weight of more than 12 pounds per gallon.

Store the tank in a dry dark place when not in use. Storage out of sunlight will prolong the life of the tank.

Do not drop, strike or kick the tank, especially at low temperatures. Tanks become brittle and are subject to cracking at temperatures below 20° Fahrenheit.

Always flush the tank with water and a neutralizing agent at the end of each use, to prevent contamination of solutions.



- Clean and rinse your pump after each use with Fimco Tank Neutralizer
- Winterize your pump or sprayer by rinsing, draining and running RV Antifreeze through it before storing for the winter.
- Use clean water for your spray mixture
- Store inside a building when not in use.



- Use to pump bleach.
- Use to pump petroleum products such as diesel fuel, gasoline or kerosene.
- Use to pump chemicals w/petroleum distillates or surfactants.
- Leave your pump sit with spray mixture in it for extended periods.
- Use dirty or unfiltered water for spraying.

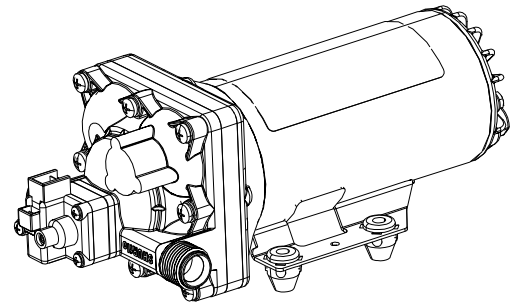
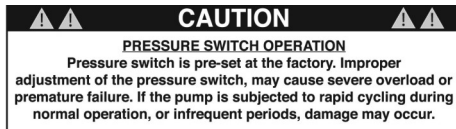

**Exploded View/Parts List:
SHURflo 12 Volt Pump, 5.3 GPM
#5151162 (Model: 5059-1310-D511)**

Troubleshooting				
Pump will not run:		Check for loose wiring	Pump surges:	Low flow may cause pump to surge
		Make sure the ON/OFF switch is on		Spray Wand is adjusted to small or fine of a spray pattern
		Check the fuse		Check for defective pressure switch
		Check for defective pressure switch		Check for leaks in the discharge line
		Check to see if connected to good 12 Volt Power Source		Check for debris in nozzle orifice
		Check for Low Voltage		Discharge hose may be too long
Pump Does Not Prime (No Discharge w/Motor Running)		Check for clogged strainer/filter	Check for clogged strainer/filter	
		Check for kinked inlet/outlet hoses	Check for worn or dirty check valve	
		Check for empty product supply	Slightly open bypass (if applicable) to overcome Pressure switch may need to be adjusted 1/4 turn at a time clockwise until surging stops	
		Check for defective check valve	Check for worn or dirty check valve	
		Check for debris in the check valve assembly	Check for empty product supply	
		Check for cracks in the pump housing	Check for Low Voltage	
Low Pressure/ Low Flow:		Check for air leaks in supply line	Pump continues to run:	Check for leaks in the discharge line
		Check for a clogged strainer		Check for defective pressure switch
		Check for proper voltage		System has leaks
		Try another 12-Volt battery		Air trapped in outlet line or pump head
		Check for leaks in the discharge line		Excessive voltage
		Check for restrictions in the discharge line		Improper adjustment of pressure switch
	Check for debris in intake	Damaged or defective wiring harness		
	Check for debris in nozzle orifice	Defective pressure switch		
	Check for worn or dirty check valve			
			Fuse blows:	

Before Troubleshooting or Attempting to Service the Pump:

- ◆ **Review Troubleshooting Chart:** Do Not attempt to repair until steps below are followed.
- ◆ **Personal Protective Gear:** Wear protective gear when servicing pump.
- ◆ **Disconnect Power:** Disconnect the power to the pump and relieve the pressure from the system.
- ◆ **Empty and Flush** pump system with water, never attempt to service the pump until it has been emptied and flushed.
- ◆ **Perform Repairs:** Follow directions provided in the troubleshooting section to repair the pump.
- ◆ **Test:** Always test the pump for leaks with plain water after any repairs before using.

Sprayer and Pump FAQs:

- ◆ **Why does the pump not run all the time?** This is an on-demand pump and only runs when a discharge is open (spray gun, bypass, boom (if applicable) or a leak is in the system).
 - ◆ **Why does the pump surge while using the spray gun?** Low flow/high pressure may cause the pump to surge (or cycle). Typically the spray wand is adjusted at too fine of a mist, to overcome, adjust the nozzle for a higher flow and/or open the bypass/control valve to achieve desired pressure.
 - ◆ **How do I adjust the pressure?** Pressure can only be adjusted by opening the pressure adjust (bypass) valve to allow some of your water or solution to return to the tank (if equipped).
 - ◆ **Pump quit and will not run, what do I need to do?** Squeeze trigger on spray gun to ensure that the system isn't just pressurized up with discharges closed.
- Check electrical connections, ensure switch is on. Check fuses. Check for proper voltage. Check pressure switch.
- ◆ **Low flow or no flow at all, what do I need to check for?** Check for a clogged or kinked intake hose and/or clogged intake strainer. Check for proper voltage.
- You will need to occasionally check your intake strainer to ensure that it is clean of any debris.
- ◆ **What is causing the fuse to blow each time I turn the pump on?** Check for excessive voltage. Improper adjustment of the pressure switch. Damaged or defective wire harness or defective pressure switch.

Warning:

Ensure the wiring harness does not become pinched or damaged in any way. This may damage the pump or cause the wiring harness to overheat, resulting in a melt down or fire.

There is a valve on the intake line. It is at this location so you can shut off the flow of solution to access your system's filter screen for cleaning and draining the tank.

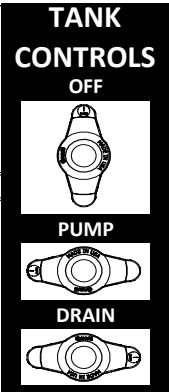
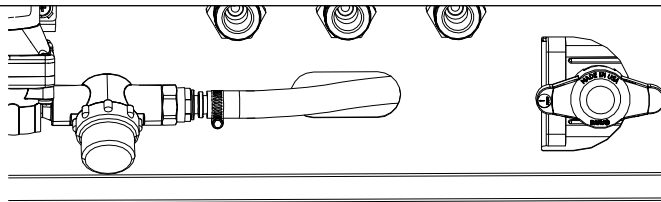

Checking/Cleaning the sprayer's filter/screen:

- ◆ Start your pump and before it shuts off, reach down and shut the valve to the "OFF" position, then shut off your pump.
- ◆ Unscrew the bowl of the filter to access the screen.
- ◆ Remove the screen and clean as necessary. Replace when done and reassemble the entire assembly.
- ◆ Make sure the valve is turned to the "Pump" position before restarting your pump.

Regulator Valve 3-Section Valve Assembly

- Fiberglass-reinforced nylon body
- Internal Parts in Delrin® and stainless steel
- Gaskets made of Viton®
- Actuator and valve body are connected by a fork coupling to facilitate maintenance operations
- Manual proportional control valve
- Female fitting for pressure gauge, 1/4" FPT

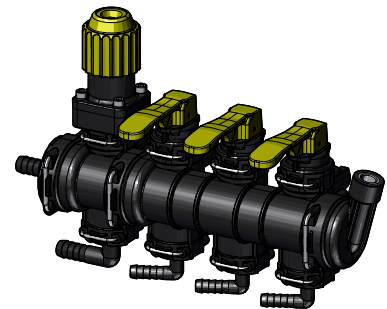

PRO SERIES Long Range Ergonomic Handguns

Technical Specifications:

- Adjustable Spray Pattern
- Aluminum Barrel
- No Drip Shut Off
- Convenient Hanger Hole
- Integrated Trigger Lock
- 600 PSI, 8 GPM
- Chemical Resistant Construction
- 38' Horizontal, 27' Vertical Maximum Spray Distance
- Adjustable On/Off Trigger Stop for Precise Spray Pattern

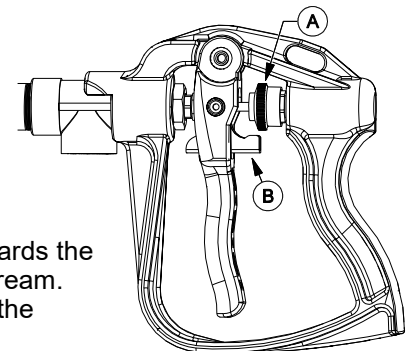

To adjust the spray pattern, the nut needs to be adjusted (Ref. A). Spinning it off, towards the lever, will make a cone pattern and spinning it on, away from the lever, will make a stream. The lever (Ref. B), is the lock that can be used to lock the lever when pulled, holding the valve open. Squeezing the trigger, will release the lock.

Exploded View
PROUTV65-12V-M
(5303225)

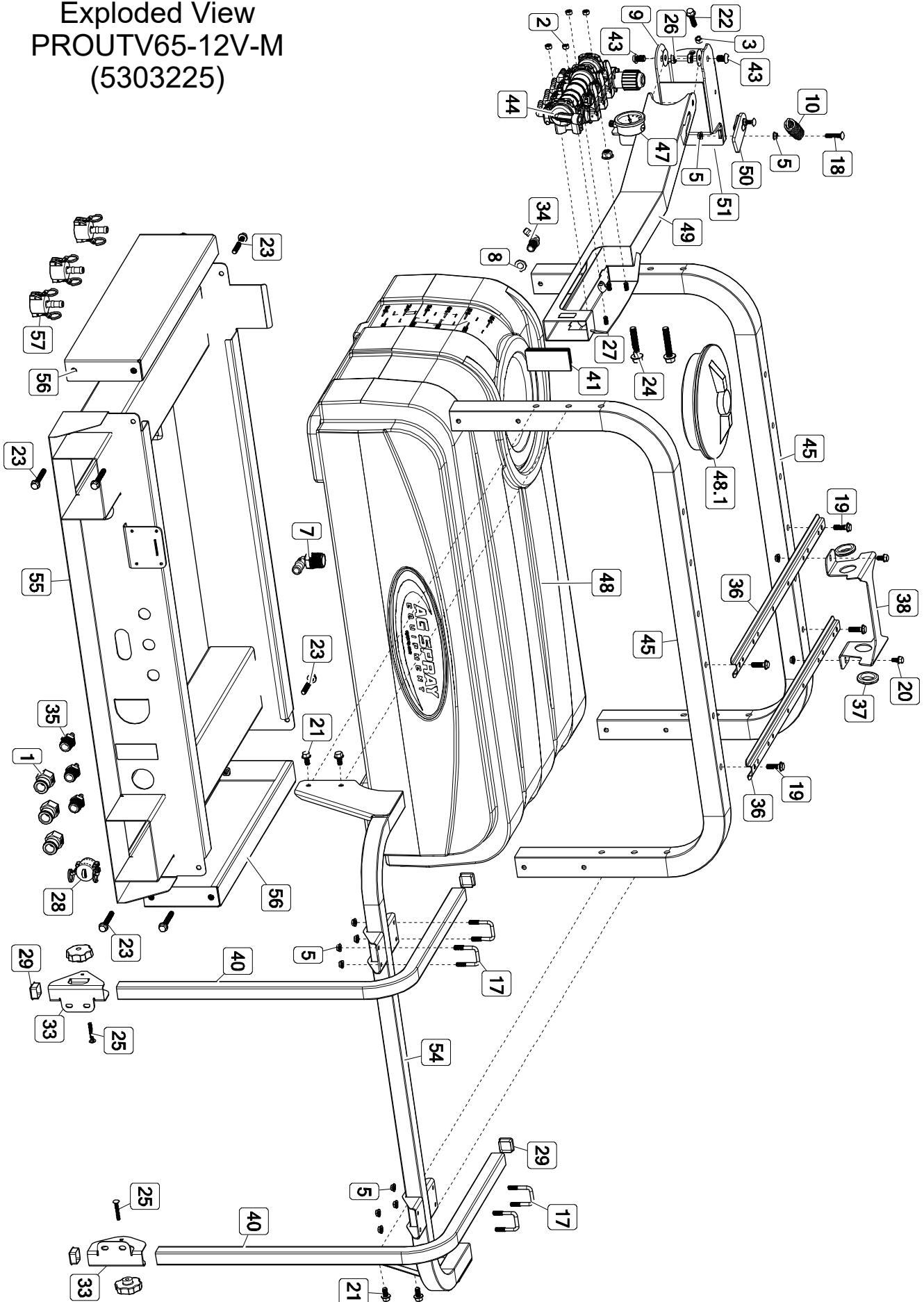

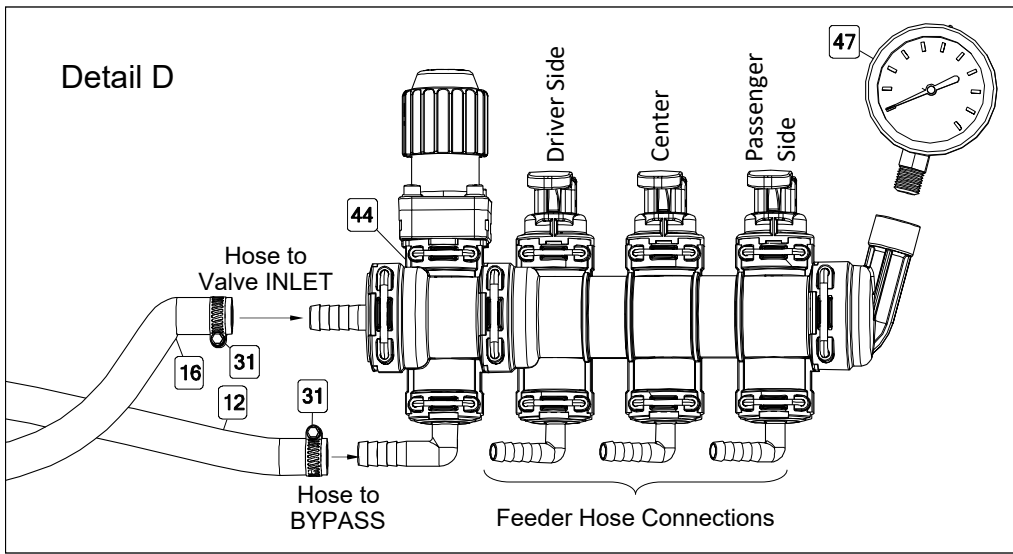
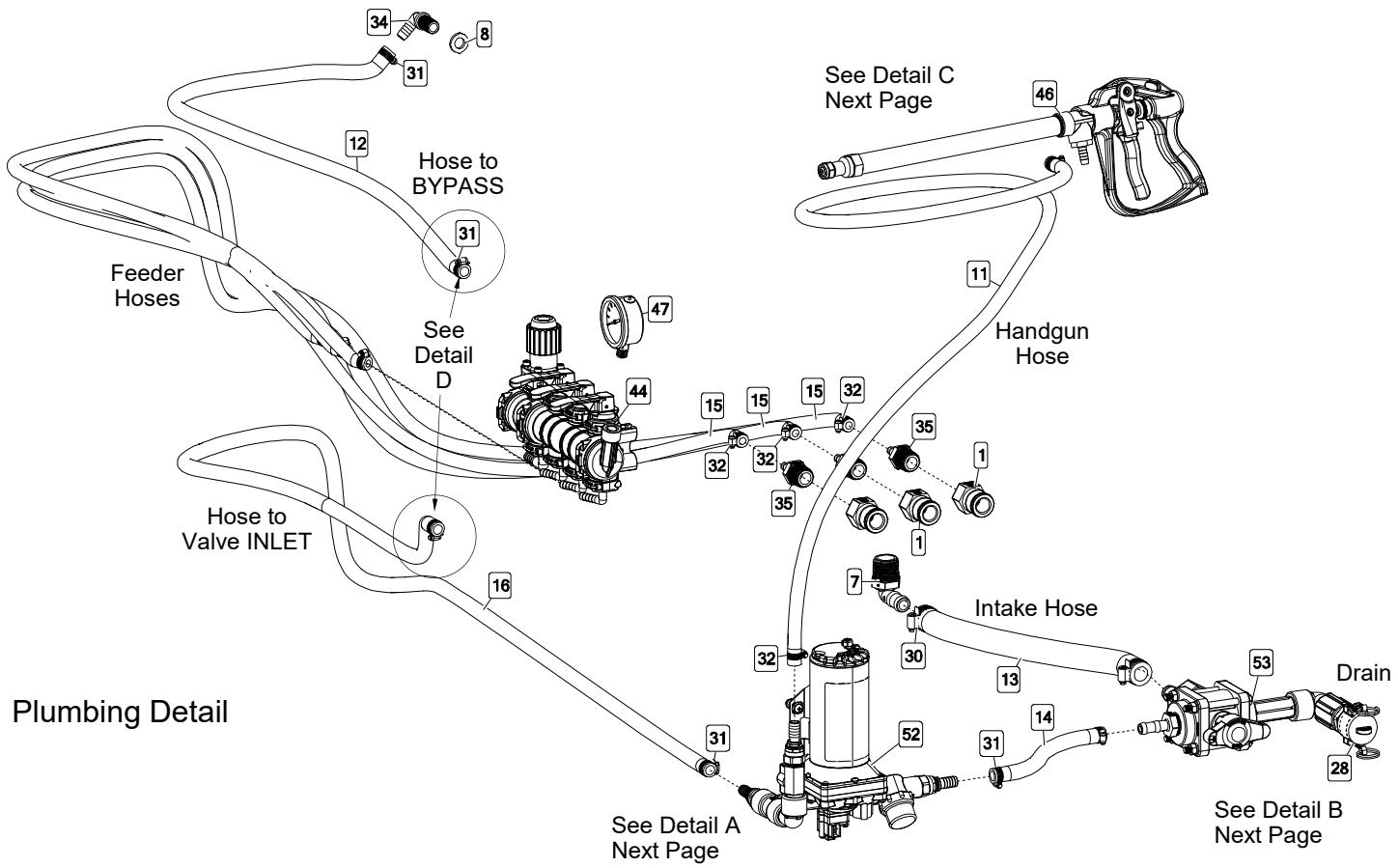

Detail A

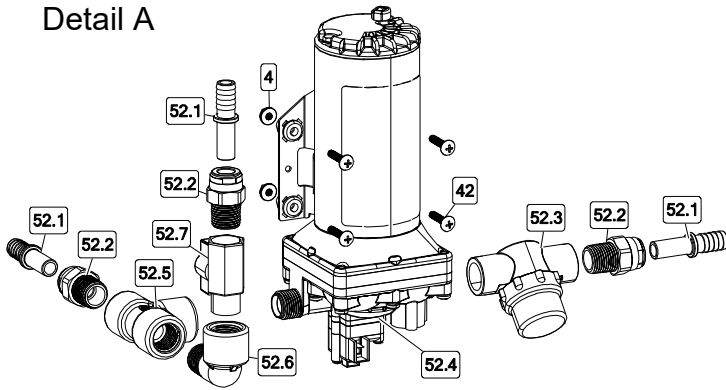

Detail C

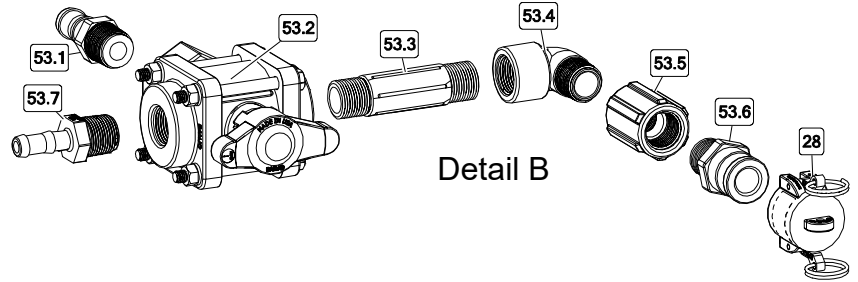
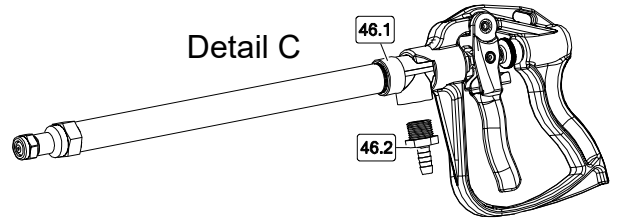

Parts List: PROUTV65-12V-M (5303225)

Ref. #	Part #	Description	Qty
1	5005156	Banjo 3/4" Male Camlock x 3/4" FPT Adapter	3
2	5006040	5/16-18 Hex Nut	4
3	5006054	3/8-16 Hex Nut	1
4	5006186	#10-24 Serrated Fling Hex Nut	4
5	5006307	5/16-18 Serrated Fling Hex Nut	12
6	5006399	1/2-13 Fling Top-Lock Hex Nut	2
7	5010335	Banjo 1" MPT x 3/4" 90° Hose Barb	1
8	5016066	1" Rubber Washer	1
9	5016321	Nylon Flat Washer, .5 ID x 1.5 OD	2
10	5019759	4" Tapered Extension Spring	1
11	5020099	Hose, 3/8"-2 Brd. x 25 Ft.	1
12	5020162	Hose, 1/2"-2 Brd. x 36"	1
13	5020300	Hose, 3/4"-2 Brd. x 18 1/2"	1
14	5020970	Hose, 1/2" x 12"	1
15	5020971	Hose, 3/8", 2-Brd x 90"	3
16	5020972	Hose, 1/2" x 76"	1
17	5034159	5/16-18 x 1.3125 x 1.875 Square U-Bolt	4
18	5034477	5/16-18 x 1.50 Carriage Bolt	1
19	5034592	3/8-16 x 1.25 Fling Hex Bolt	4
20	5034634	5/16-18 x 0.625 Fling Hex Bolt	2
21	5034660	3/8-16 x 0.75 Fling Hex Bolt	4
22	5034663	3/8-16 x 1.50 Fling Hex Bolt	1
23	5034668	3/8-16 x 2.75 Fling Hex Bolt (Full Thread)	8
24	5034697	1/2-13 x 2.75 Fling Hex Bolt (Full Thread)	2
25	5034807	1/4-20 x 1.75 Carriage Bolt	2
26	5034863	1/2-13 Low Profile Nylon Lock Nut	2
27	5034867	5/16"-18 x 3/4" Button Head Screw	4
28	5046090	Banjo 3/4" Female Camlock Lever Dust Cap	1
29	5046448	Square Cap, Black (1 1/4" Square Tube)	4
30	5051024	Hose Clamp, 3/4"	2
31	5051114	Hose Clamp (3/8"-1/2")	6
32	5051144	Hose Clamp (3/8")	8
33	5051151	Boom Clamp	2
34	5056095	Polypropylene Elbow, 11/16" U.N.F. x 1/2" HB	1
35	5067181	Banjo 3/4" MPT x 3/8" HB	3
36	5070152	Pro UTV Mounting Strut	2
37	5075014	Rubber Grommet (Black)	2
38	5078833	Handgun Bracket	1

Ref. #	Part #	Description	Qty
39	5088026	5 Lobe Knob 1/4-20UNC	2
40	5095395	UTV Boom Mount	2
41	5102137	Rectangle Cap Plug 2" x 4"	1
42	5117168	#10-24 x 1.00 PH Truss Head Screw	4
43	5117351	1/2-13 Button Head Screw, 3/4" Thread	2
44	5143555	Regulator Valve, 3-Section Valve Assembly	1
45	5144150	65 Gallon Hoop	2
46	5163150	22" HP Spray Gun with 3/8" Hose Barb	1
46.1	5163136	High Pressure Aluminum Spray Gun 22"	1
46.2	5067130	Poly Fitting, 1/2" MNPT x 3/8" HB	1
47	5167031	Gauge, Liquid-Filled, 0-100 PSI	1
48	5169356	65 Gallon Pro UTV Tank (Yellow)	1
48.1	60032	Norwesco 8" Lid w/Vent & Ring	1
49	5281969	Manual Control Arm Weldment	1
50	5281971	Control Arm Detent Plate	1
51	5281972	Manual Control Arm Mount Weldment	1
52	5281973	Pro UTV 12V Pump Assembly	1
52.1	5149209	Push-to-Connect 1/2" x 1/2" HB Fitting	3
52.2	5149208	1/2" Tube x 1/2" Male NPTF-Black	3
52.3	5116476	Inline Strainer, 1/2" FNPT, 50 Mesh Viton	1
52.4	5151162	ShurFlo 5.3 GPM Diaphragm 12V Pump, 1/2" MPT	1
52.5	5010308	Banjo 1/2" MNPT Tee Fitting	1
52.6	5010295	Banjo 1/2" MPT x 1/2" FPT 90° Street Elbow	1
52.7	90FMB12	1/2" FNPT x 1/2" MNPT Ball Valve, w/Butterfly Knob	1
53	5281974	Pro UTV Valve/Strainer Assembly, 12V	1
53.1	5067184	Poly Fitting, 3/4" MNPT x 3/4" HB	1
53.2	BJBLV075	Banjo 3/4" 3-Way Bottom Load Valve	1
53.3	5011164	Banjo 3/4" x 4" Poly Pipe Nipple	1
53.4	5010296	Banjo 3/4" MPT x 3/4" FPT 90° Street Elbow	1
53.5	5010322	Banjo 3/4" FPT x 3/4" FPT Pipe Coupling	1
53.6	5005158	Banjo Male Adapter, 3/4" MNPT	1
53.7	5067182	Banjo 3/4" MPT x 1/2" HB	1
54	5281975	Boom Mount Weldment	1
55	5281999	Pro UTV Frame Weldment, 12V	1
56	5282427	Pro UTV Frame Side Cover	2
57	BJ050C	b3/4" female camlock, 1/2" hb	3

Exploded View
PROUTV105-12V-M
(5303230)

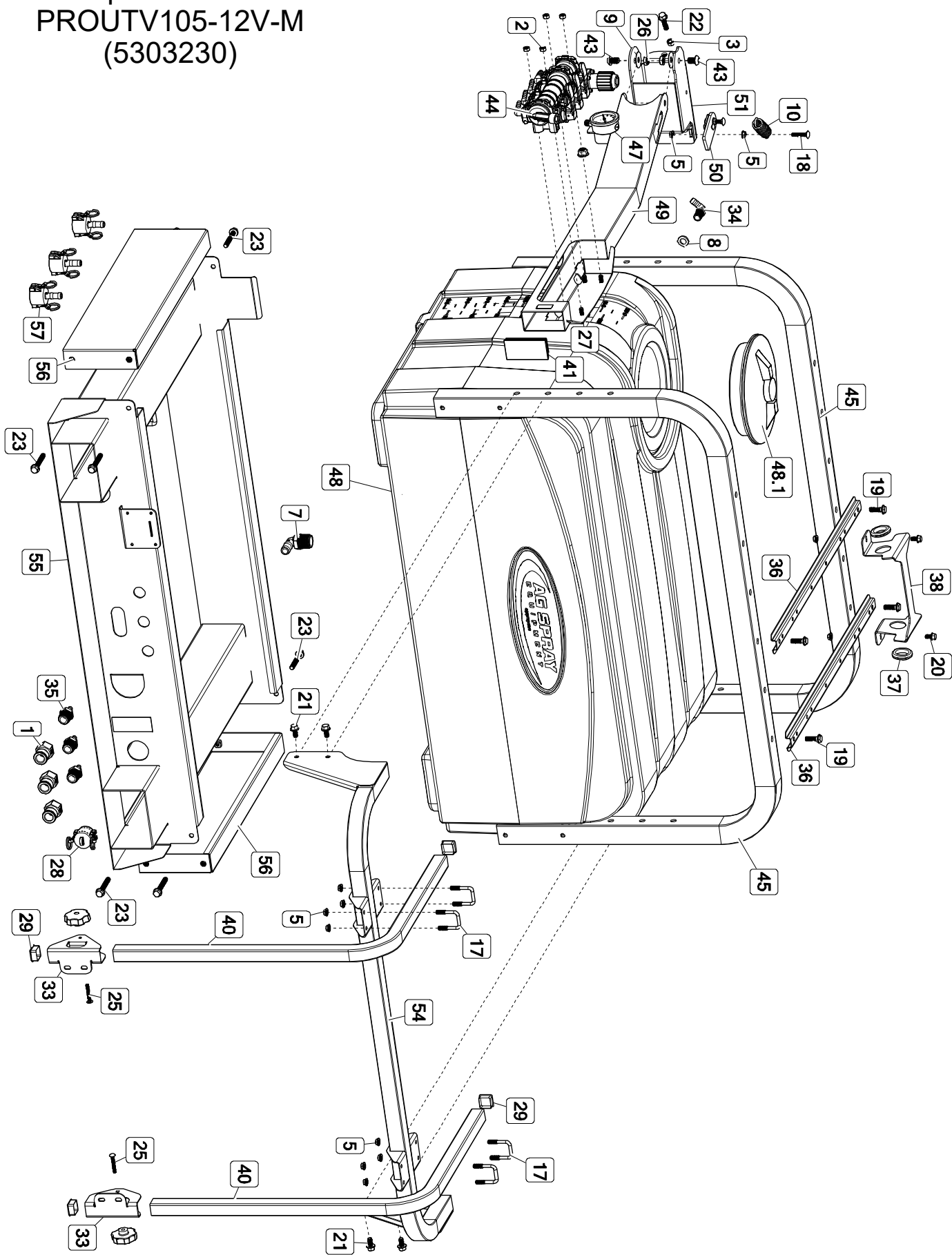

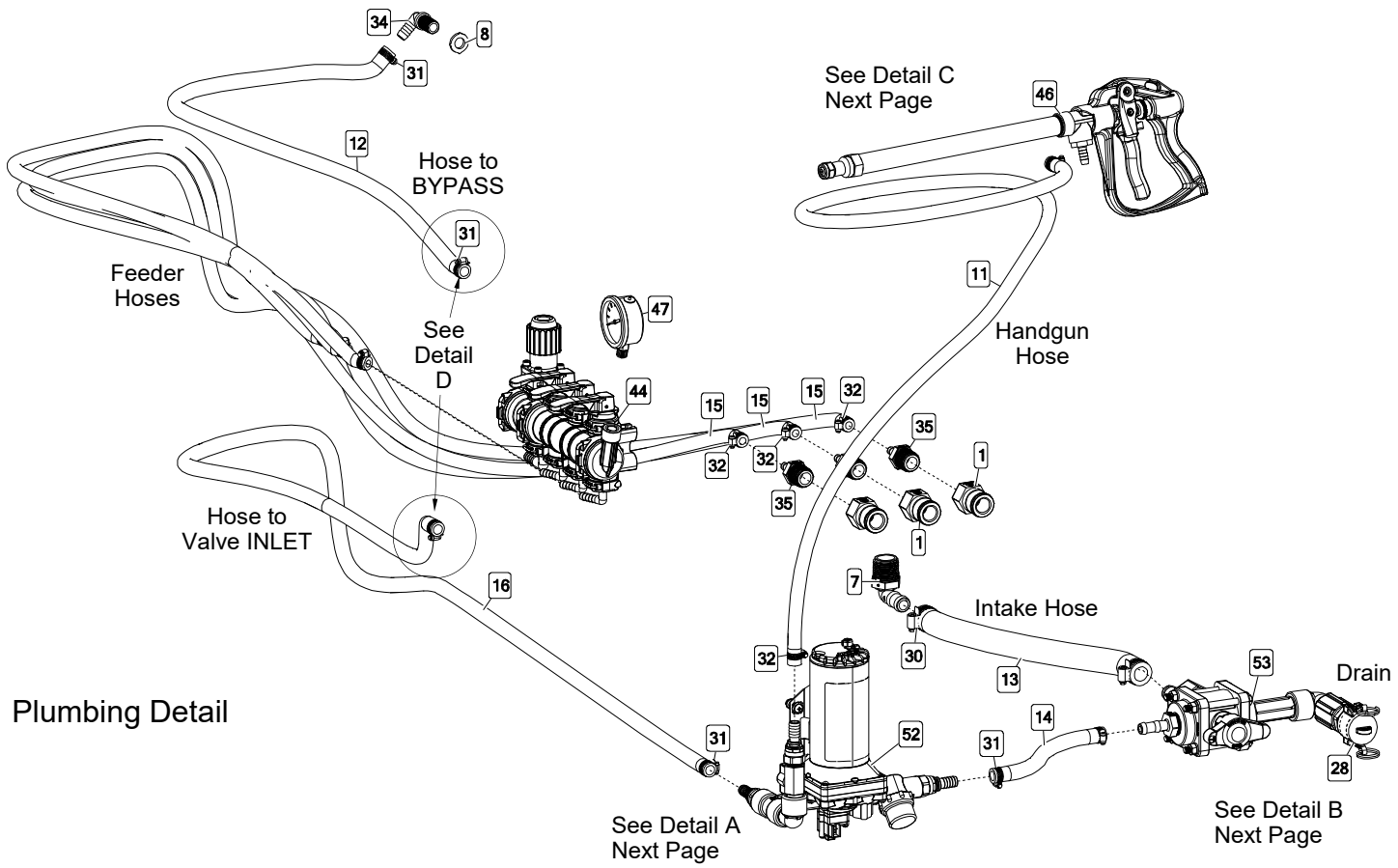

Plumbing Detail

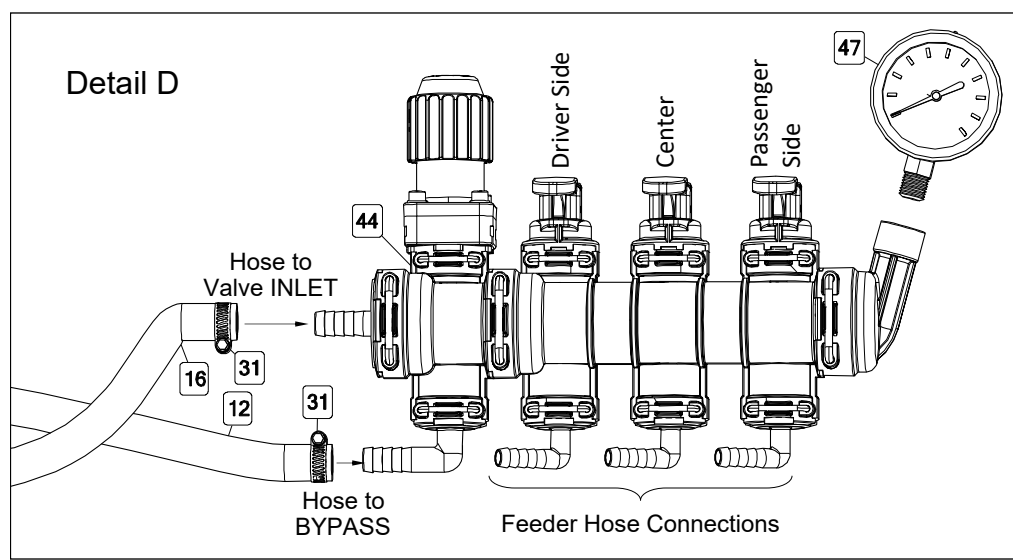

Detail A

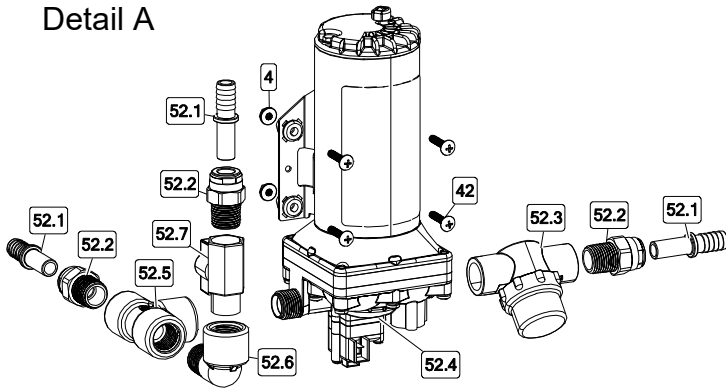

Detail C

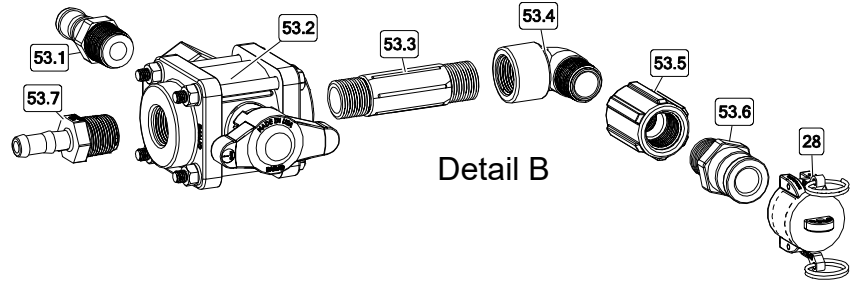
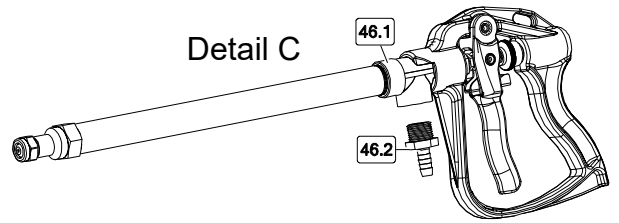

Parts List: PROUTV105-12V-M (5303230)

Ref. #	Part #	Description	Qty
1	5005156	Banjo 3/4" Male Camlock x 3/4" FPT Adapter	3
2	5006040	5/16-18 Hex Nut	4
3	5006054	3/8-16 Hex Nut	1
4	5006186	#10-24 Serrated Fling Hex Nut	4
5	5006307	5/16-18 Serrated Fling Hex Nut	12
6	5006399	1/2-13 Fling Top-Lock Hex Nut	2
7	5010335	Banjo 1" MPT x 3/4" 90° Hose Barb	1
8	5016066	1" Rubber Washer	1
9	5016321	Nylon Flat Washer, .5 ID x 1.5 OD	2
10	5019759	4" Tapered Extension Spring	1
11	5020099	Hose, 3/8"-2 Brd. x 25 Ft.	1
12	5020298	Hose, 1/2"-2 Brd. x 48"	1
13	5020300	Hose, 3/4"-2 Brd. x 18 1/2"	1
14	5020970	Hose, 1/2" x 12"	1
15	5020971	Hose, 3/8", 2-Brd x 90"	3
16	5020972	Hose, 1/2" x 76"	1
17	5034159	5/16-18 x 1.3125 x 1.875 Square U-Bolt	4
18	5034477	5/16-18 x 1.50 Carriage Bolt	1
19	5034592	3/8-16 x 1.25 Fling Hex Bolt	4
20	5034634	5/16-18 x 0.625 Fling Hex Bolt	2
21	5034660	3/8-16 x 0.75 Fling Hex Bolt	4
22	5034663	3/8-16 x 1.50 Fling Hex Bolt	1
23	5034668	3/8-16 x 2.75 Fling Hex Bolt (Full Thread)	8
24	5034697	1/2-13 x 2.75 Fling Hex Bolt (Full Thread)	2
25	5034807	1/4-20 x 1.75 Carriage Bolt	2
26	5034863	1/2-13 Low Profile Nylon Lock Nut	2
27	5034867	5/16"-18 x 3/4" Button Head Screw	4
28	5046090	Banjo 3/4" Female Camlock Lever Dust Cap	1
29	5046448	Square Cap, Black (1 1/4" Square Tube)	4
30	5051024	Hose Clamp, 3/4"	2
31	5051114	Hose Clamp (3/8"-1/2")	6
32	5051144	Hose Clamp (3/8")	8
33	5051151	Boom Clamp	2
34	5056095	Polypropylene Elbow, 11/16" U.N.F. x 1/2" HB	1
35	5067181	Banjo 3/4" MPT x 3/8" HB	3
36	5070152	Pro UTV Mounting Strut	2
37	5075014	Rubber Grommet (Black)	2
38	5078833	Handgun Bracket	1

Ref. #	Part #	Description	Qty
39	5088026	5 Lobe Knob 1/4-20UNC	2
40	5095395	UTV Boom Mount	2
41	5102137	Rectangle Cap Plug 2" x 4"	1
42	5117168	#10-24 x 1.00 PH Truss Head Screw	4
43	5117351	1/2-13 Button Head Screw, 3/4" Thread	2
44	5143555	Regulator Valve, 3-Section Valve Assembly	1
45	5144151	105 Gallon Hoop	1
46	5163150	22" HP Spray Gun with 3/8" Hose Barb	1
46.1	5163136	High Pressure Aluminum Spray Gun 22"	1
46.2	5067130	Poly Fitting, 1/2" MNPT x 3/8" HB	1
47	5167031	Gauge, Liquid-Filled, 0-100 PSI	1
48	5169358	105 Gallon Pro UTV Tank (Yellow)	1
48.1	60032	Norwesco 8" Lid w/Vent & Ring Assembly	1
49	5281969	Manual Control Arm Weldment	1
50	5281971	Control Arm Detent Plate	1
51	5281972	Manual Control Arm Mount Weldment	1
52	5281973	Pro UTV 12V Pump Assembly	1
52.1	5149209	Push-to-Connect 1/2" x 1/2" HB Fitting	3
52.2	5149208	1/2" Tube x 1/2" Male NPTF-Black	3
52.3	5116476	Inline Strainer, 1/2" FNPT, 50 Mesh Viton	1
52.4	5151162	ShurFlo 5.3 GPM Diaphragm 12V Pump, 1/2" MPT	1
52.5	5010308	Banjo 1/2" FNPT Tee Fitting	1
52.6	5010295	Banjo 1/2" MPT x 1/2" FPT 90° Street Elbow	1
52.7	90FMB12	1/2" FNPT x 1/2" MNPT Ball Valve, w/Butterfly Knob	1
53	5281974	Pro UTV Valve/Strainer Assembly, 12V	1
53.1	5067184	Poly Fitting, 3/4" MNPT x 3/4" HB	1
53.2	BJBLV075	Banjo 3/4" 3-Way Bottom Load Valve	1
53.3	5011164	Banjo 3/4" x 4" Poly Pipe Nipple	1
53.4	5010296	Banjo 3/4" MPT x 3/4" FPT 90° Street Elbow	1
53.5	5010322	Banjo 3/4" FPT x 3/4" FPT Pipe Coupling	1
53.6	5005158	Banjo Male Adapter, 3/4" MNPT	1
53.7	5067182	Banjo 3/4" MPT x 1/2" HB	1
54	5281975	Boom Mount Weldment	1
55	5281999	Pro UTV Frame Weldment, 12V	1
56	5282427	Pro UTV Frame Side Cover	2
57	BJ050C	b3/4" female camlock, 1/2" hb	3

Dimensions:

PROUTV65-12V-M (5303225)

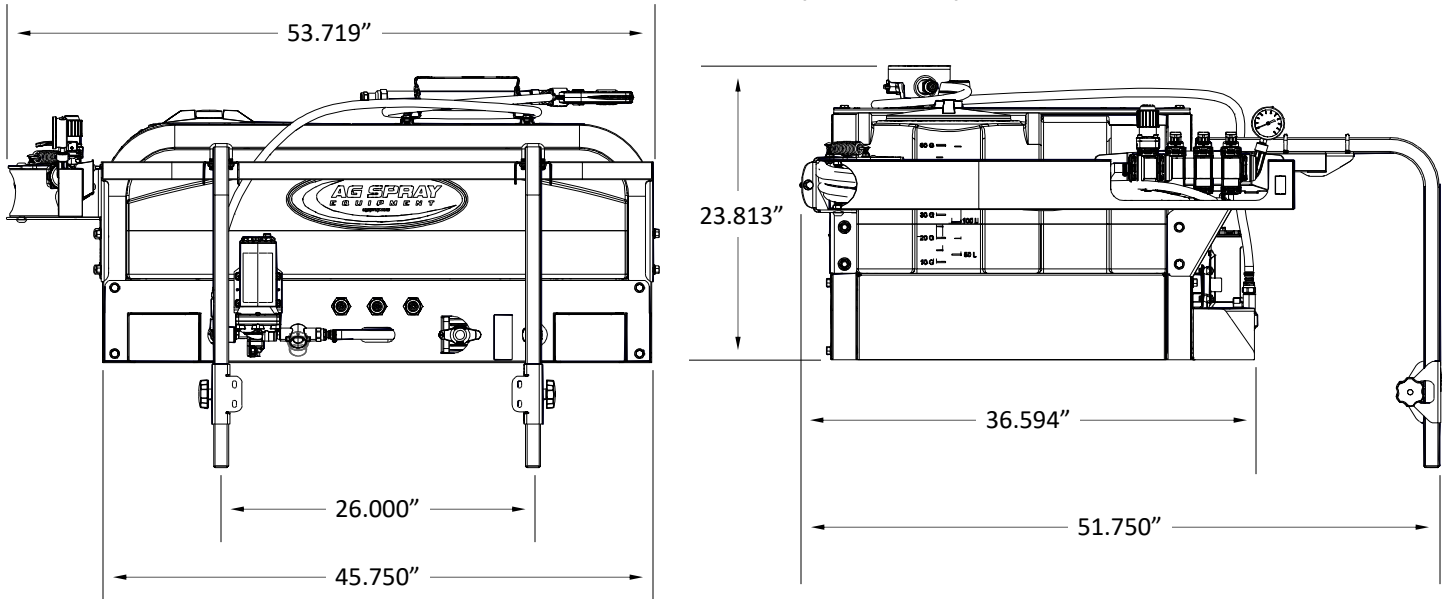

PROUTV105-12V-M (5303230)

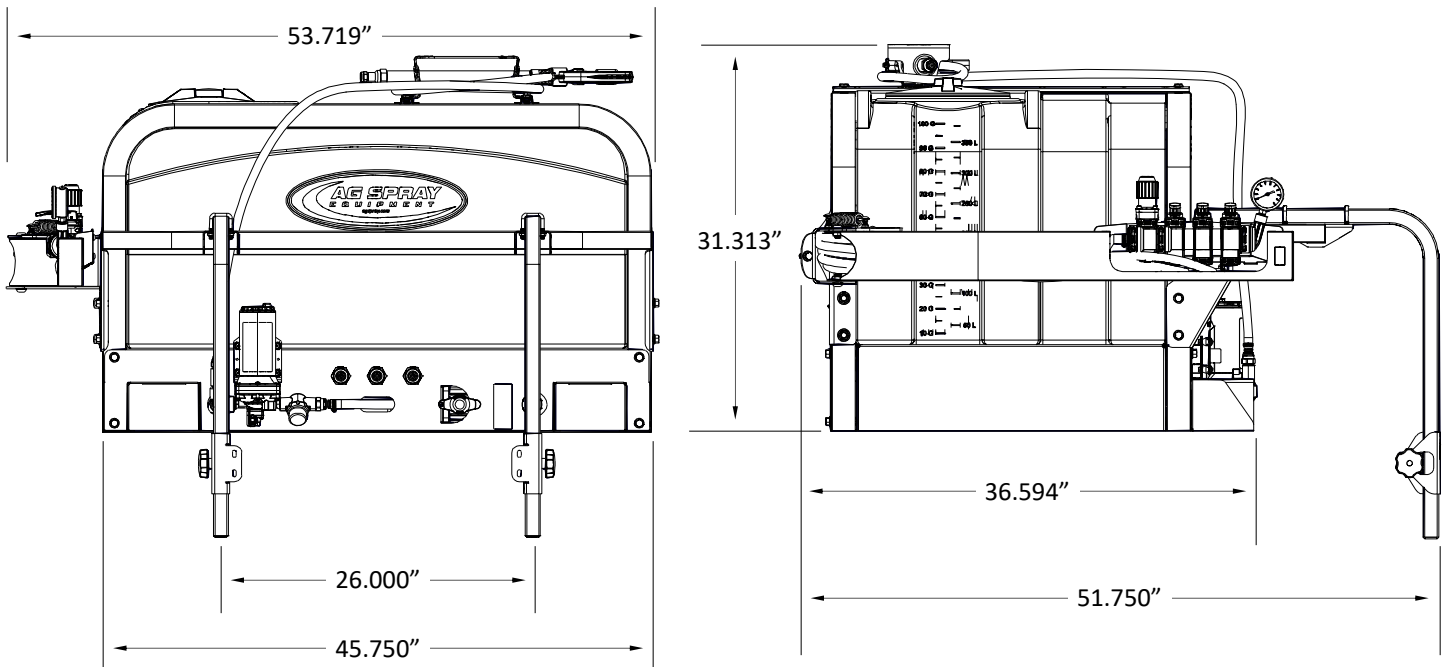

Warranty

LIMITED WARRANTY FOR NEW AG SPRAY EQUIPMENT

WHO MAY USE THIS LIMITED WARRANTY. This limited warranty (the "Limited Warranty") is provided by Ag Spray Equipment to the original purchaser ("you") of the Equipment (as defined below) from Ag Spray Equipment or one of Ag Spray Equipment's authorized dealers. This Limited Warranty does not apply to any subsequent owner or other transferee of the Equipment. THIS LIMITED WARRANTY GIVES YOU SPECIFIC LEGAL RIGHTS, AND YOU MAY ALSO HAVE OTHER RIGHTS WHICH VARY FROM STATE TO STATE.

WHAT THIS LIMITED WARRANTY COVERS AND FOR HOW LONG. Ag Spray Equipment warrants that any new Equipment will be free from defects in material and workmanship for a period of **one (1) year** (homeowner), **90 days** (commercial user), after delivery of the Equipment to you (the "Warranty Period"). Warranty Period is not extended if Ag Spray Equipment repairs or replaces the Equipment.

WHAT IS NOT COVERED BY THIS LIMITED WARRANTY. This Limited Warranty does not apply to: (1) used Equipment; (2) any Equipment that has been altered, changed, repaired or treated since its delivery to you, other than by Ag Spray Equipment or its authorized dealers; (3) damage or depreciation due to normal wear and tear; (4) defects or damage due to failure to follow Ag Spray Equipment's operator's manual, specifications or other written instructions, or improper storage, operation, maintenance, application or installation of parts; (5) defects or damage due to misuse, accident or neglect, "acts of God" or other events beyond Ag Spray Equipment's reasonable control; (6) accessories, attachments, tools or parts that were not manufactured by Ag Spray Equipment, whether or not sold or operated with the Equipment; or (7) rubber parts, such as tires, hoses and grommets.

HOW TO OBTAIN WARRANTY SERVICE. To obtain warranty service under this Limited Warranty, you must (1) provide written notice to Ag Spray Equipment of the defect during the Warranty Period and within **thirty (30)** days after the defect becomes apparent or the repair becomes necessary, at the following address: Ag Spray Equipment, 1000 Fimco Lane, North Sioux City, SD 57049; and (2) make the Equipment available to Ag Spray Equipment or an authorized dealer within a reasonable period of time. For more information about this Limited Warranty, please call: **800-274-1025** or your local Ag Spray location.

WHAT REMEDIES ARE AVAILABLE UNDER THIS LIMITED WARRANTY. If the conditions set forth above are fulfilled and the Equipment or any part thereof is found to be defective, Ag Spray Equipment shall, at its own cost, and at its option, either repair or replace the defective Equipment or part. Ag Spray Equipment will pay for shipping and handling fees to return the repaired or replacement Equipment or part to you.

LIMITATION OF IMPLIED WARRANTIES AND OTHER REMEDIES. THE REMEDIES DESCRIBED ABOVE ARE YOUR SOLE AND EXCLUSIVE REMEDIES, AND AG SPRAY EQUIPMENT'S SOLE LIABILITY, FOR ANY BREACH OF THIS LIMITED WARRANTY. TO THE EXTENT APPLICABLE, ANY IMPLIED WARRANTIES, INCLUDING, WITHOUT LIMITATION, THE IMPLIED WARRANTIES OF MERCHANTABILITY AND FITNESS FOR A PARTICULAR PURPOSE, SHALL BE LIMITED IN DURATION TO THE WARRANTY PERIOD, AND THE REMEDIES AVAILABLE FOR BREACH THEREOF SHALL BE LIMITED TO THE REMEDIES AVAILABLE UNDER THIS EXPRESS LIMITED WARRANTY. SOME STATES DO NOT ALLOW LIMITATIONS ON HOW LONG AN IMPLIED WARRANTY LASTS, SO THE ABOVE LIMITATION MAY NOT APPLY TO YOU. IN NO EVENT SHALL AG SPRAY EQUIPMENT'S LIABILITY UNDER THIS LIMITED WARRANTY EXCEED THE ACTUAL AMOUNT PAID BY YOU FOR THE DEFECTIVE EQUIPMENT, NOR SHALL AG SPRAY EQUIPMENT BE LIABLE, UNDER ANY CIRCUMSTANCES, FOR ANY CONSEQUENTIAL, INCIDENTAL, SPECIAL OR PUNITIVE DAMAGES OR LOSSES, WHETHER DIRECT OR INDIRECT. SOME STATES DO NOT ALLOW THE EXCLUSION OR LIMITATION OF INCIDENTAL OR CONSEQUENTIAL DAMAGES, SO THE ABOVE LIMITATION OR EXCLUSION MAY NOT APPLY TO YOU.