

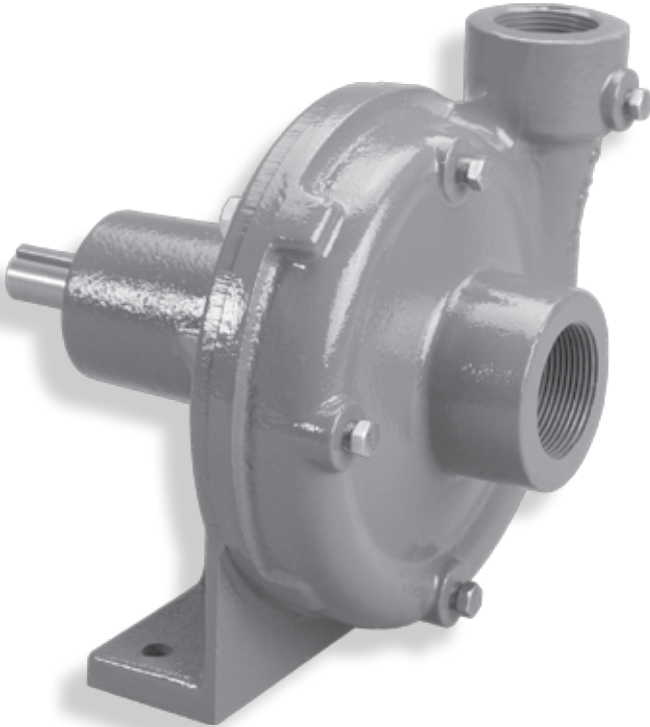

# Heavy Duty Frame Mounted Centrifugal Pump



## FMC-CW-150-X

- Suction 1-1/2" - Discharge 1-1/4"
- Clockwise Rotation when Facing Shaft End
- Chemical Resistant Valox® or Optional Cast Iron Impeller
- 3/4" Diameter Stainless Steel Shaft
- Heavy Duty Bearings
- Standard Viton® Carbon/Ceramic seal or Optional Severe Duty Silicon Carbide Mechanical Seal

® Valox is a registered trademark of GE Plastics.

® Viton is a registered trademark of DuPont Dow Elastomers.

## PERFORMANCE CHART

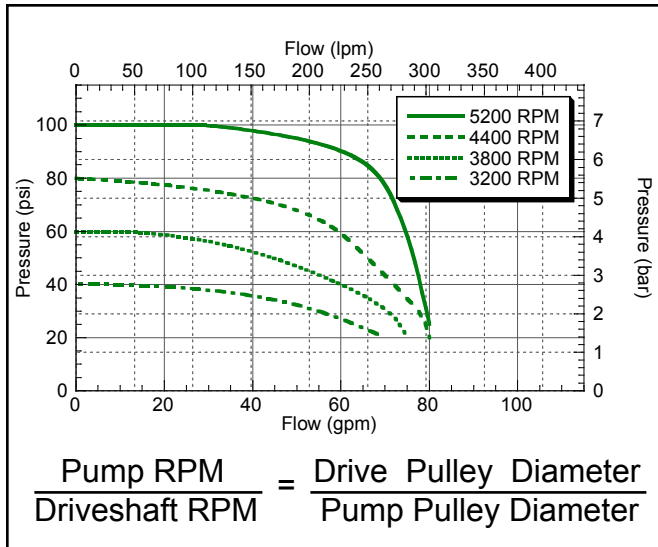

## DIMENSIONS

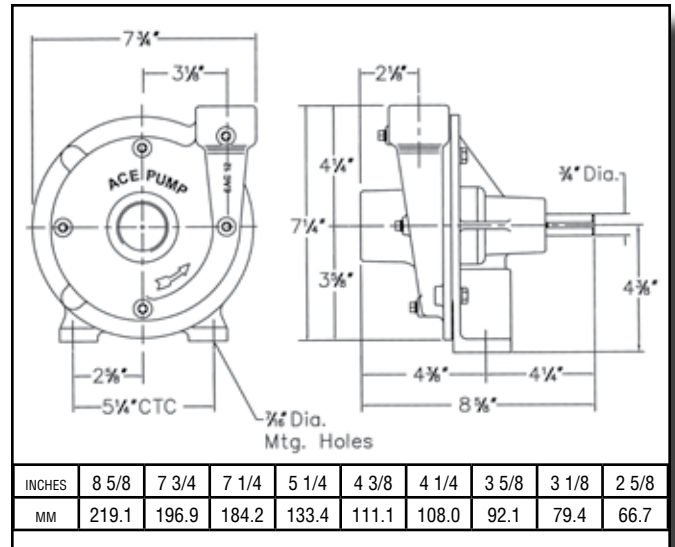



# FMC-CW-150-X

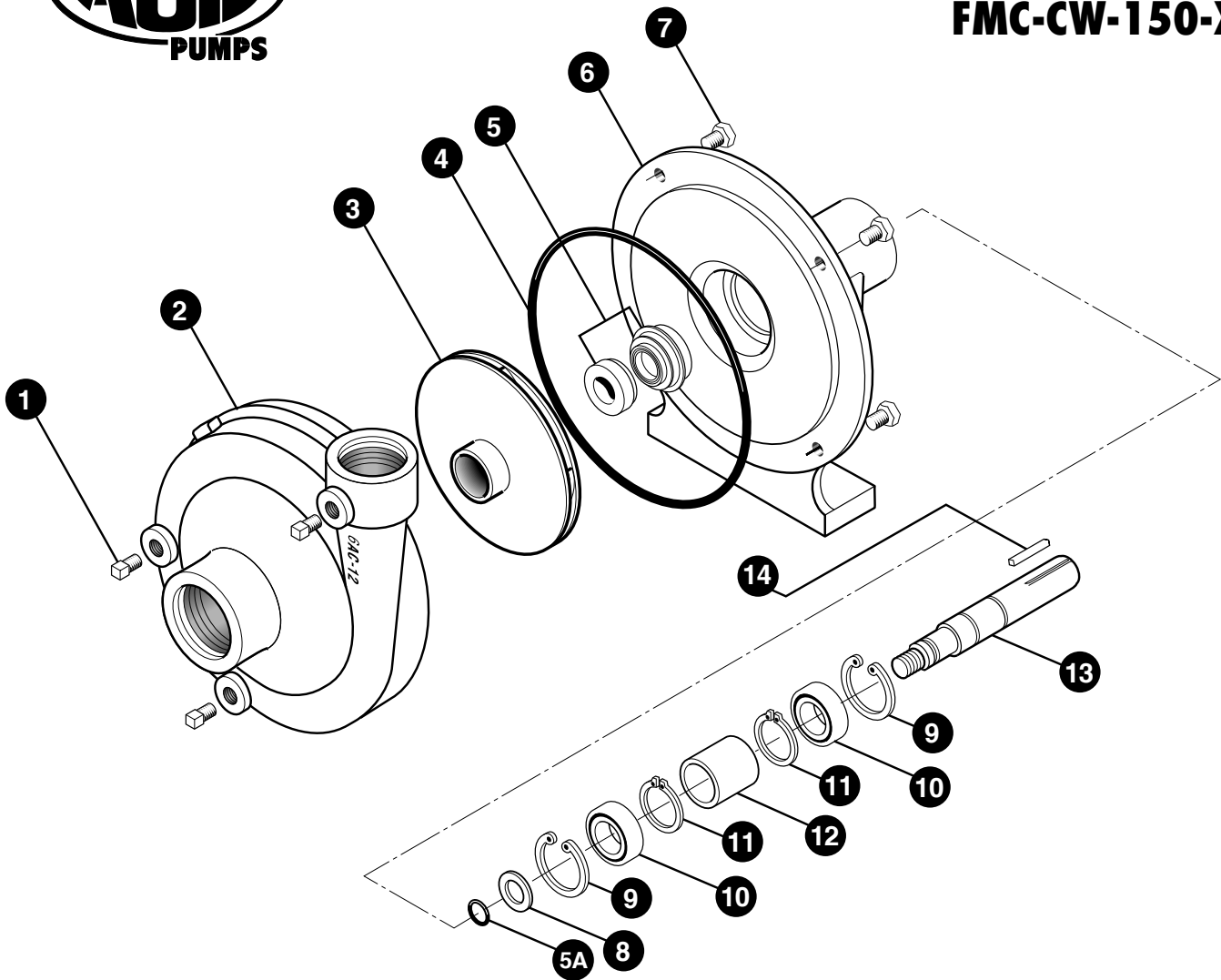

REF. #	PART #	EDP #	DESCRIPTION	REQ.
1	BAC-53	41110	Pipe plug, 1/8" NPT	4
1	41120	41120	Pipe plug, 1/8" NPT, stainless steel (optional)	4
2	6AC-12	30130	Volute, 1-1/2" x 1-1/4", clockwise rotation, cast iron	1
3	BAC-26-CW-150-P	41510	Impeller, 5-1/2" dia., right hand NF thread, thermoplastic	1
3	BAC-26-CW-150-CI	41515	Impeller, 5-1/2" dia., right hand NF thread, cast iron (optional)	1
4 <sup>①②</sup>	BAC-4A	40005	"O" Ring for BAC-12 volute seal, effective Apr. '96	1
4	BAC-4	40010	Gasket, 4 hole	1
5 <sup>①</sup>	BAC-7V	40151	Seal, Viton mechanical seal, includes 40160 "O" ring	1
5 <sup>②</sup>	BAC-7SC	40152	Seal, Silicon carbide mechanical seal, includes 40160 "O" Ring (optional)	1
5A <sup>①②</sup>	40160	40160	"O" Ring for BAC-6 shaft	1
6	BAC-14X-F	40309	Mounting frame	1
7	40930	40930	Cap screw, 3/8" NC x 3/4" Hex head, stainless steel (optional)	4
7	40950	40950	Cap screw, 3/8" NC x 3/4" Hex head	4
8	BAC-54	41130	Slinger	1
9	BAC-33X	40812	Snap ring, internal, BAC-14 mounting frame	2
10	BAC-37X	40872	Bearing, BAC-6 driven shaft	2
11	BAC-32X	40792	Snap ring, external, BAC-6 driven shaft	2
12	BAC-32X-S	40796	Spacer for BAC-6 shaft	1
13	BAC-6X-CW-SS	41504	Shaft, 5/8" Driven, right hand NF thread, stainless steel	1
14	BAC-50	41080	Key, 3/16" x 3/16" x 1 1/4"	1
①	RK-FMC	52700	Repair kit for FMC series	-
②	RK-FMCS	52706	Repair kit for FMC series with silicon carbide seal	-